

# VICTOR

## ASSEMBLING INSTRUCTIONS

---

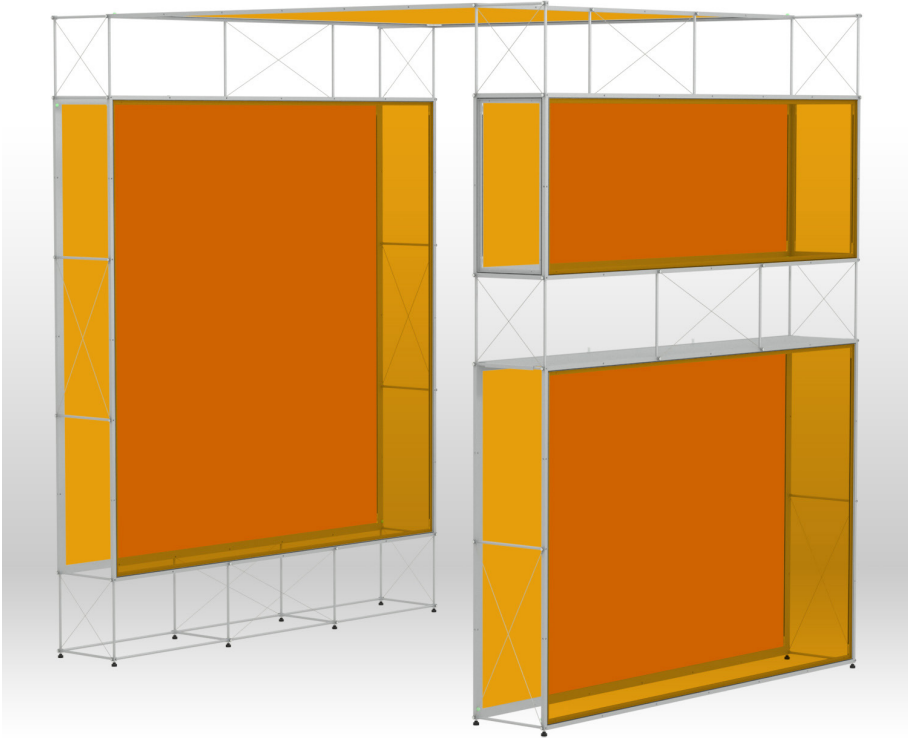



**OPEN BOX 1**

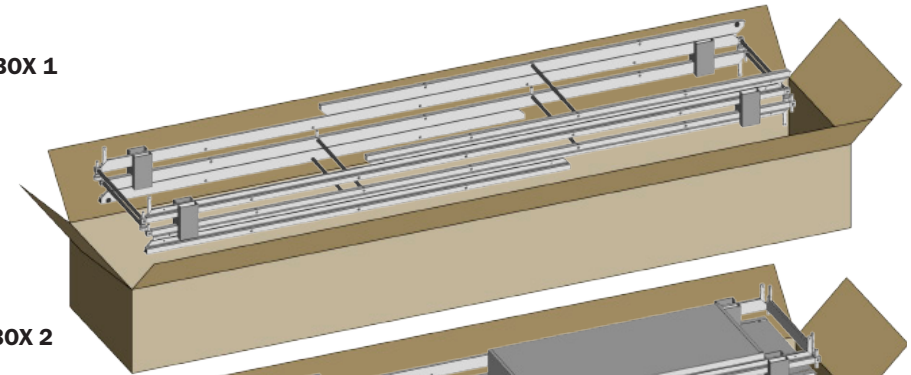

**OPEN BOX 2**

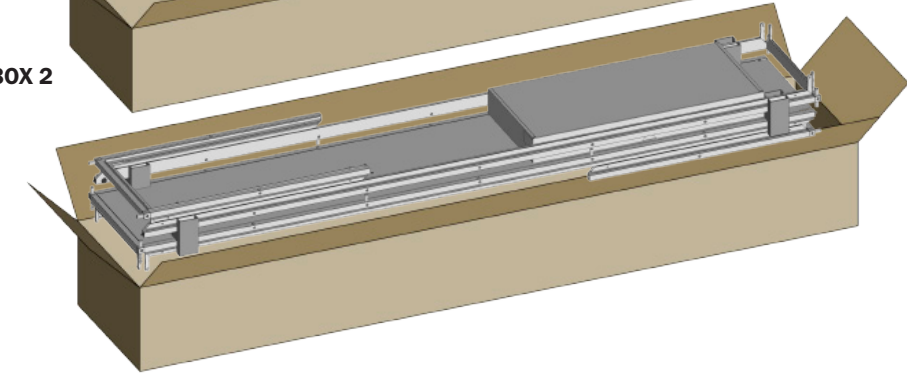

**4 CLIC UP FRAMES**

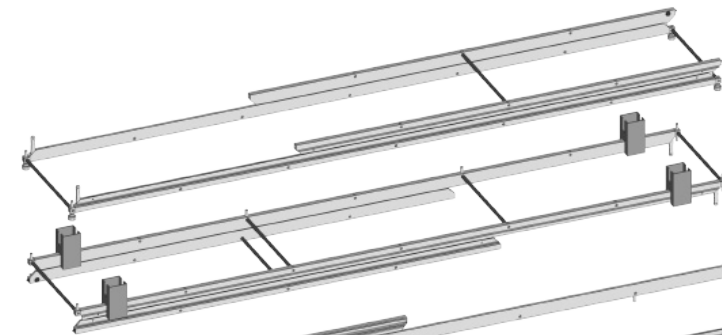

**VI-01**

**VI-02**

**VI-03**

**MATERIAL BOX**

**VI-04**

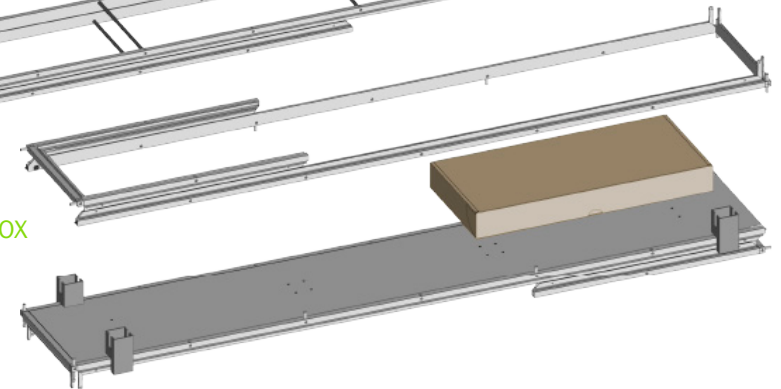

# VICTOR

## ASSEMBLING INSTRUCTIONS



**1**

UNFOLD VI-01 / VI-02

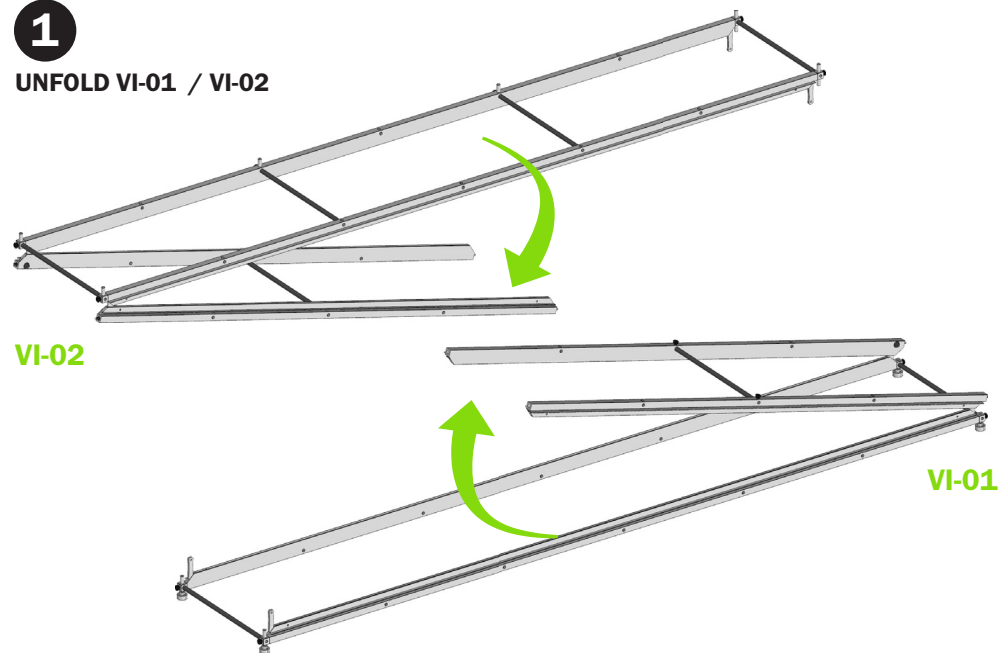

**3**

CONNECT CLIC TUBES  
MAGNETICALLY WITH FRAME

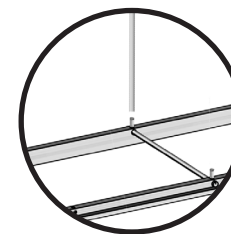

**MATERIAL BOX WITH:**  
clic cubes,  
height adjusters  
tubes A600 x  $\varnothing$ 10 mm  
tubes A300 x  $\varnothing$ 10 mm

A300 mm

**2**

CONNECT VI-01 / VI-02

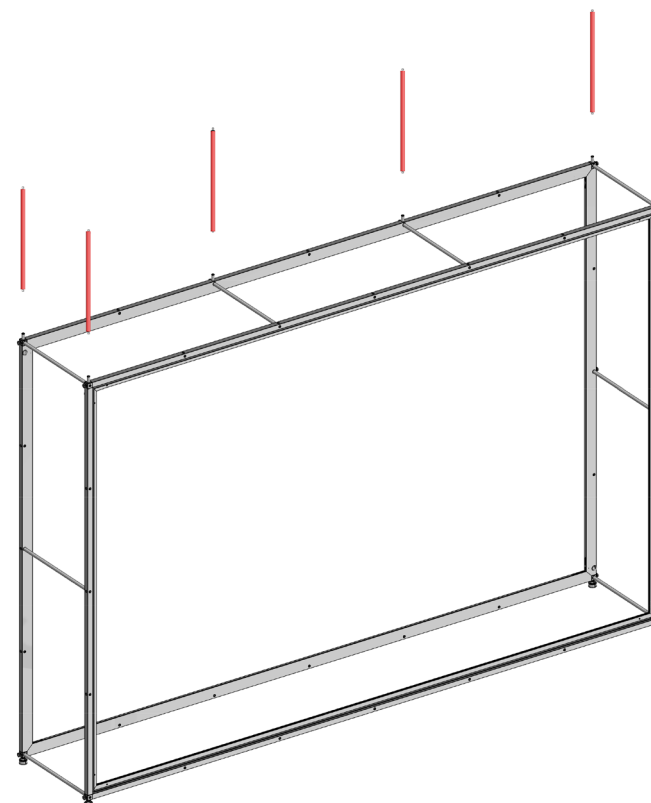
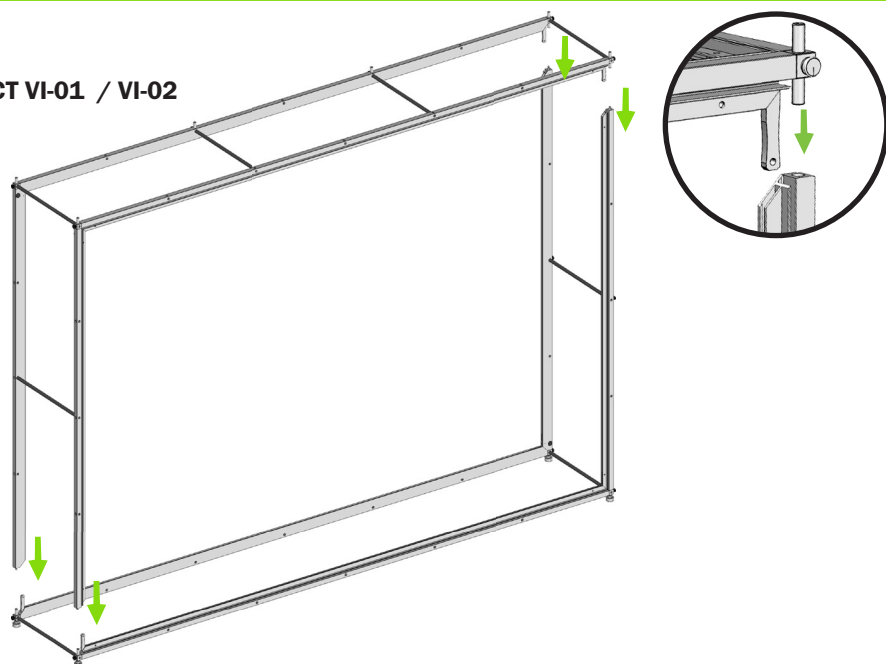



**4**

**CONNECT VI-03 TO TUBES**

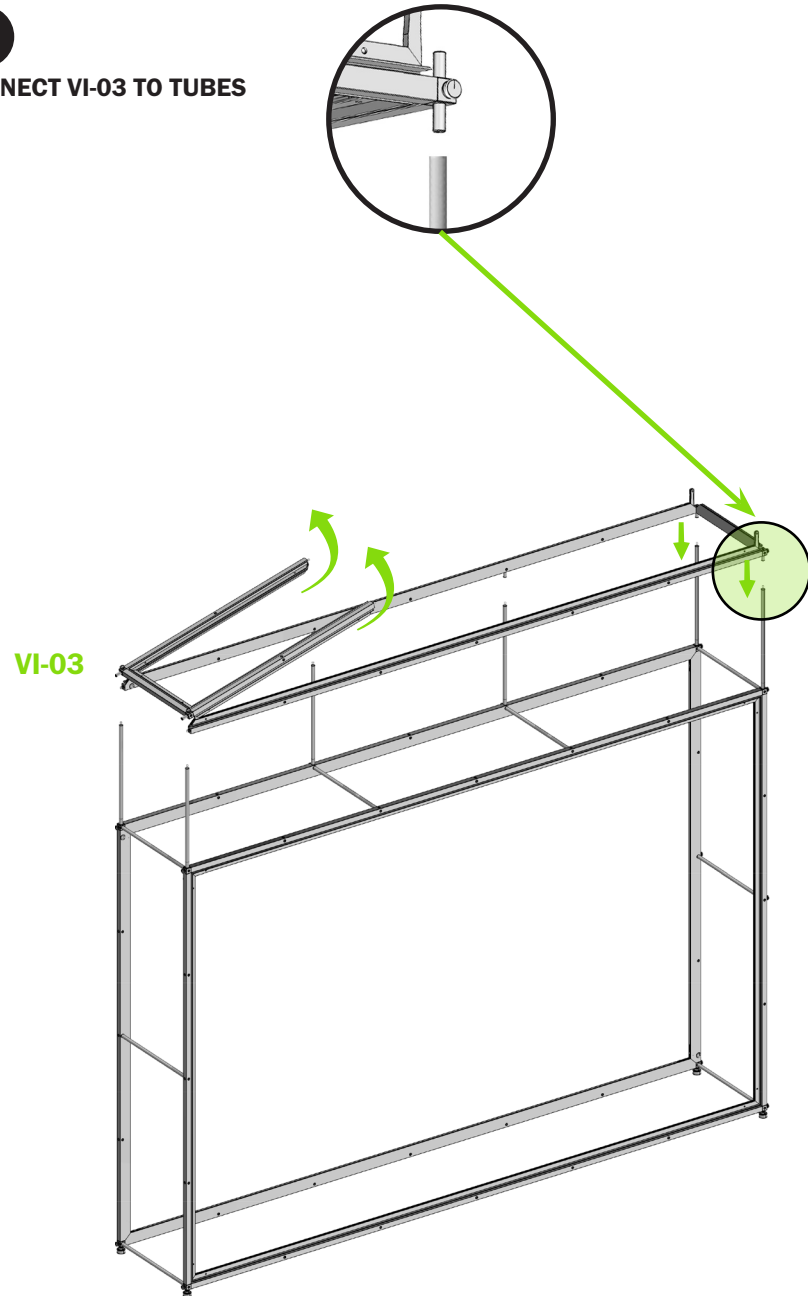

**5**

**1 CONNECT VI-04 FIRST**

**2 THEN LIFT FRAME**

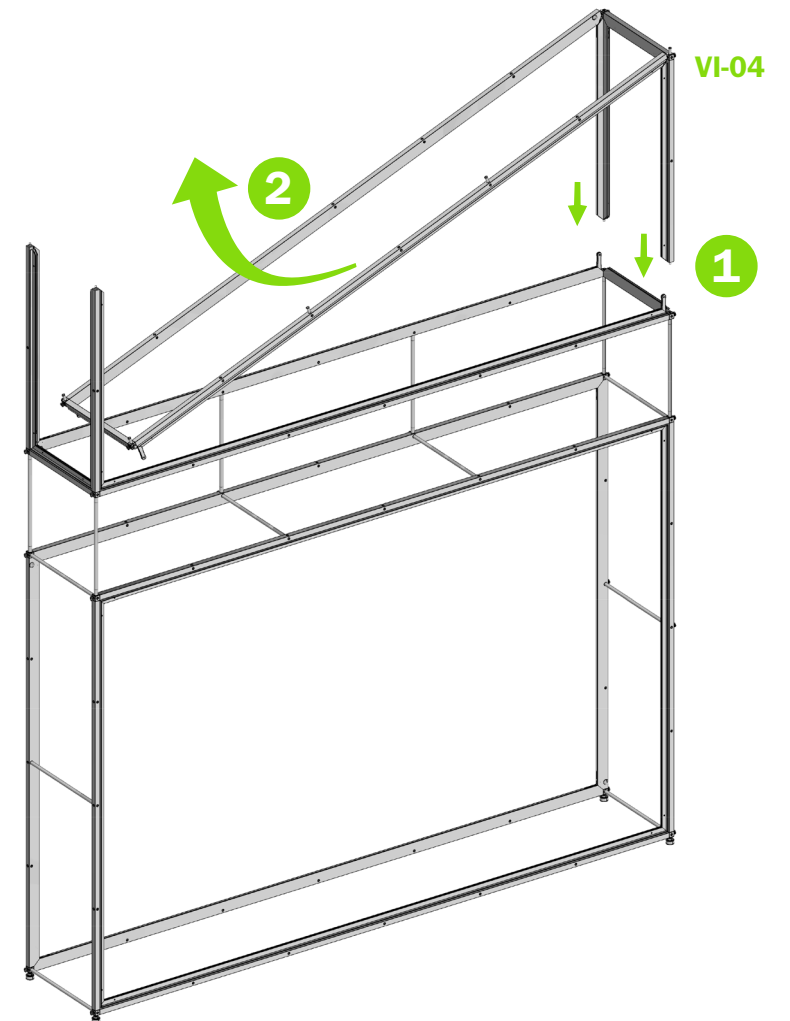

6

CONNECT CLIC TUBES  
MAGNETICALLY WITH FRAME

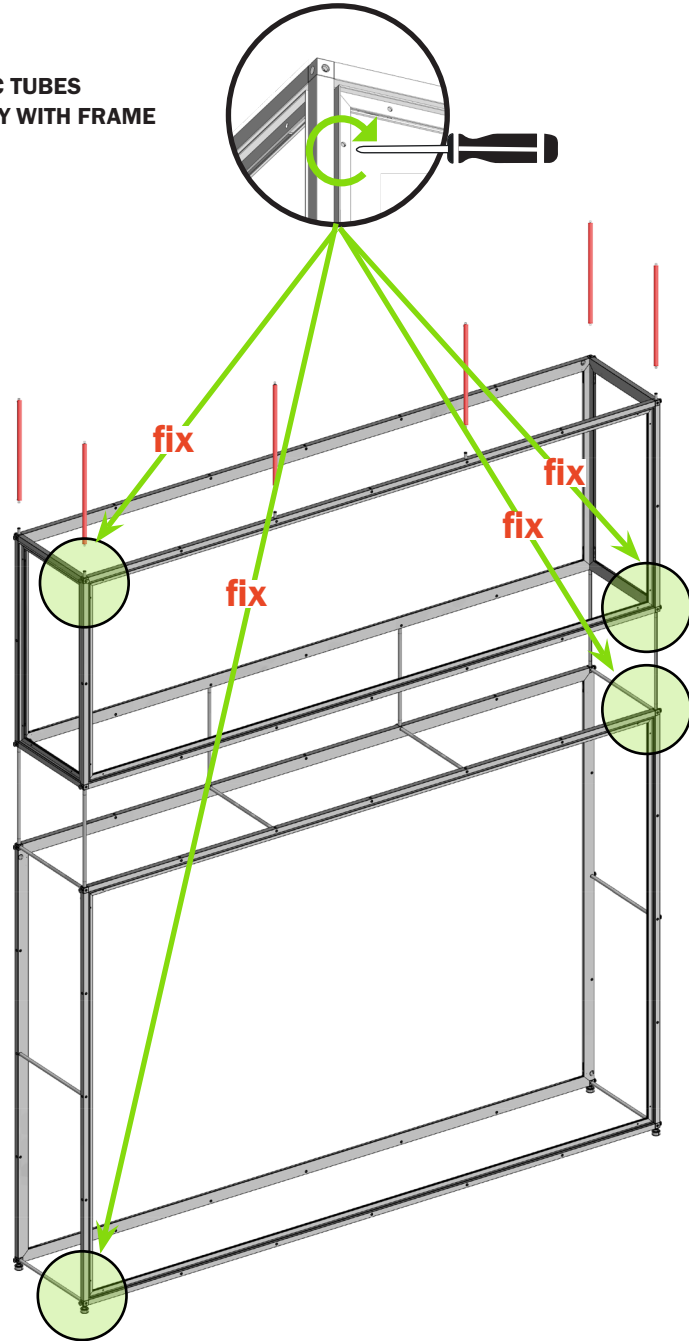

7

CONNECT CEILING PROFILE TO TUBES  
MAGNETICALLY

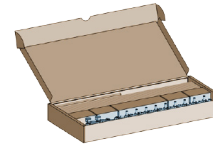

**MATERIAL BOX MIT:**  
clic Würfeln,  
Höhenverstellern  
Rohren A600 x ø10 mm  
Rohren A300 x ø10 mm

A300 mm

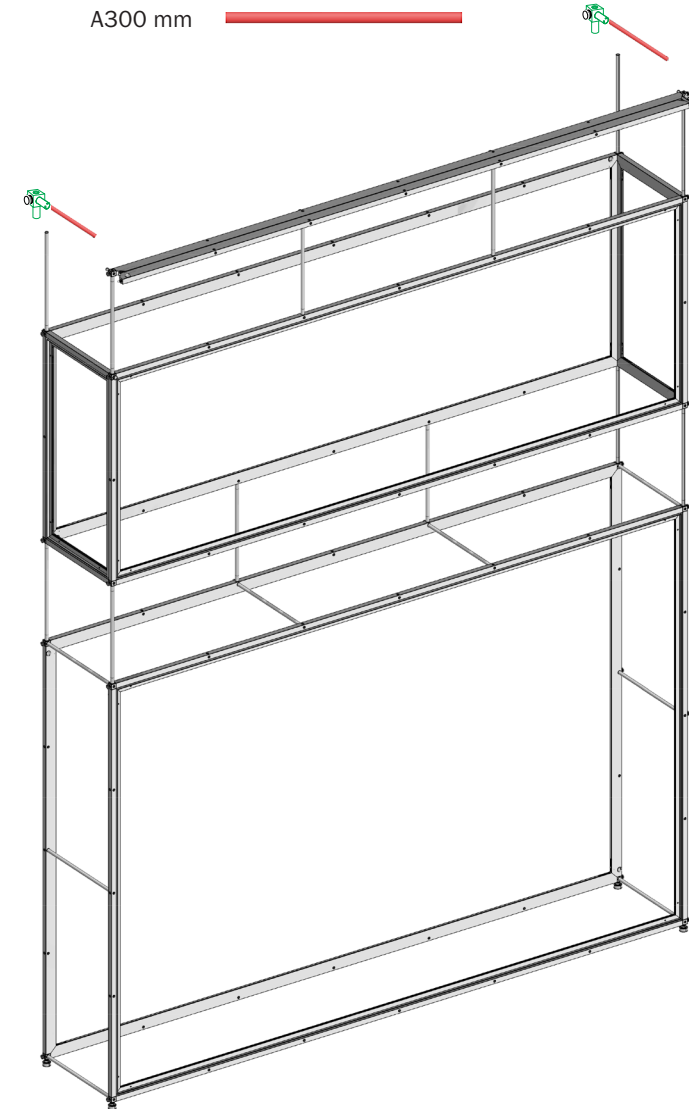

2 PIECES C

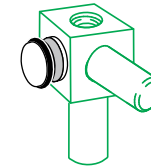



**8**

OPEN BOX 3

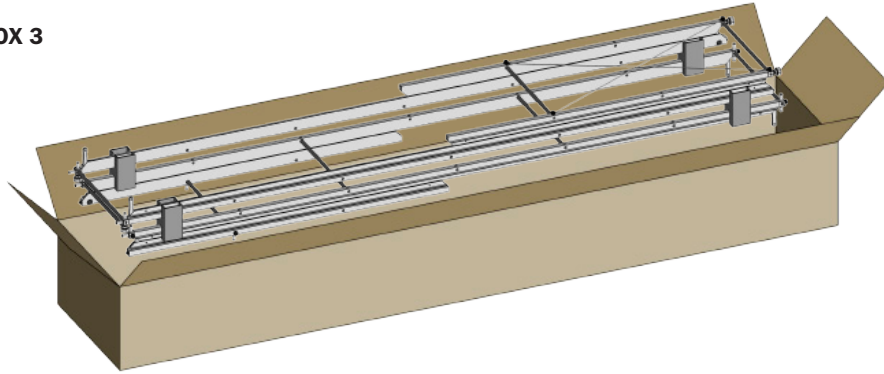

VI-05

VI-06

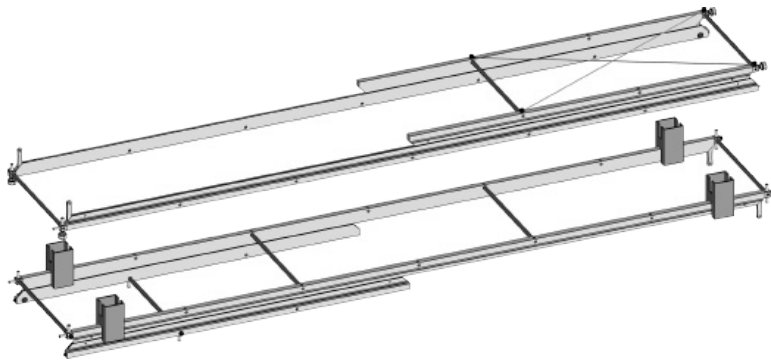

**9**

UNFOLD FRAME VI-05 / VI 06

VI-05

VI-06

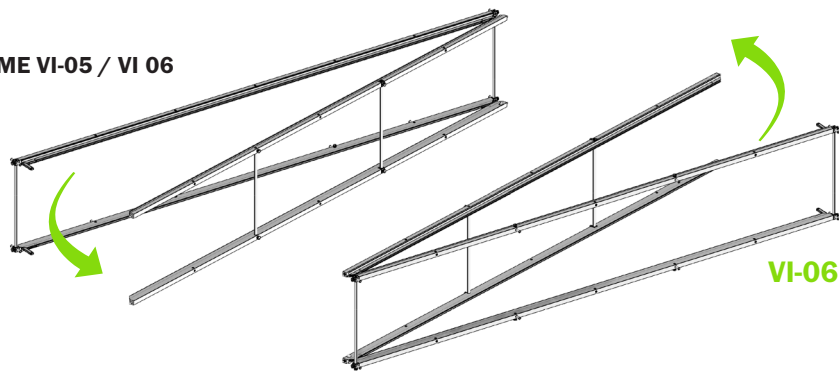

**10**

CONNECT FRAME VI-05 / VI 06

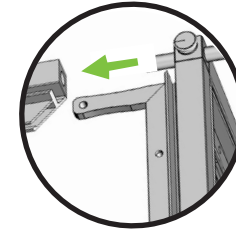

VI-06

VI-05

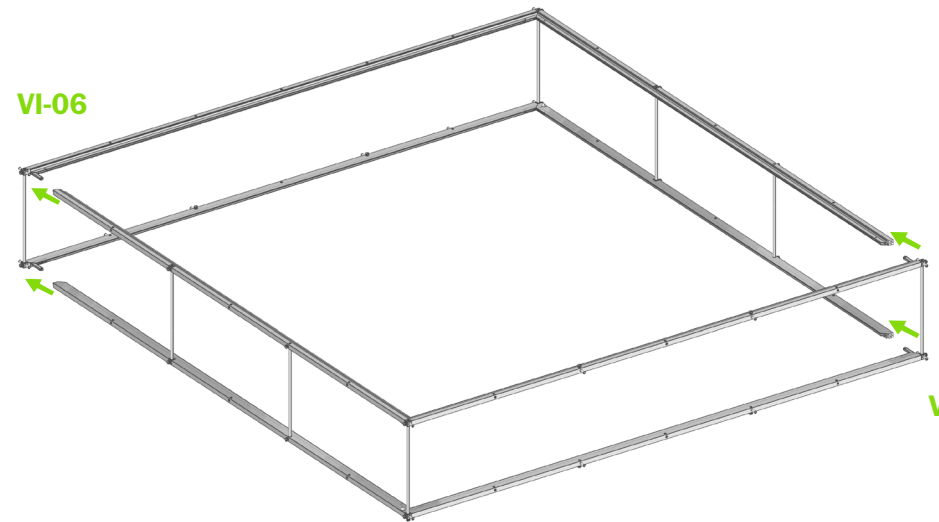

# VICTOR

## ASSEMBLING INSTRUCTIONS

11

CONNECT CLIC TUBES MAGNETICALLY  
WITH HEIGHT ADJUSTORS (CONNECTORS)

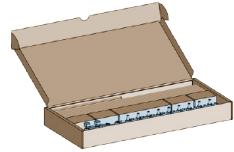
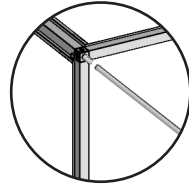

**MATERIAL BOX WITH:**  
clik cubes,  
height adjusters  
tubes A600 x  $\varnothing$ 10 mm  
tubes A300 x  $\varnothing$ 10 mm

A600 mm   
A300 mm 

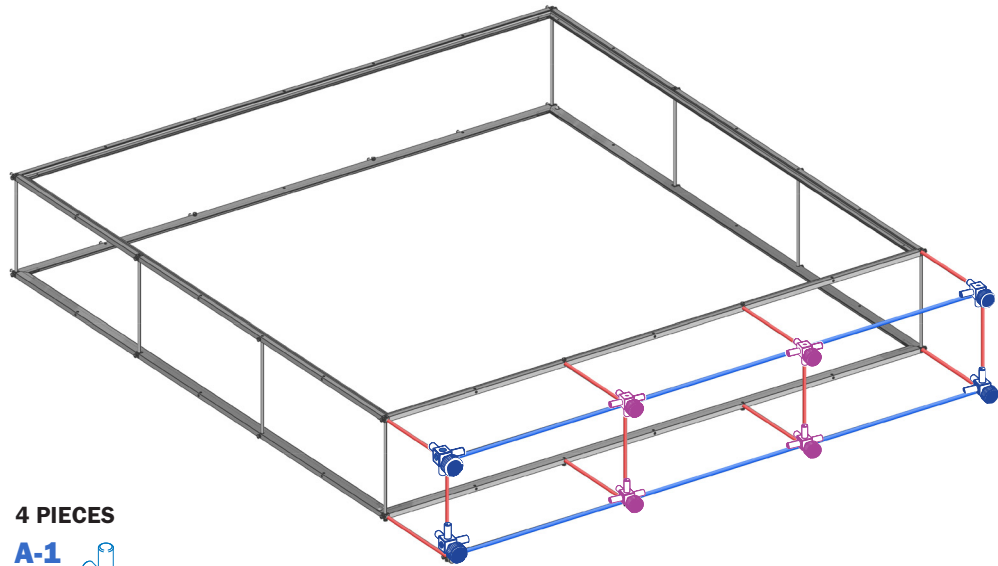

4 PIECES

A-1



4 PIECES

A 2



12

LIFT THE UNIT UP

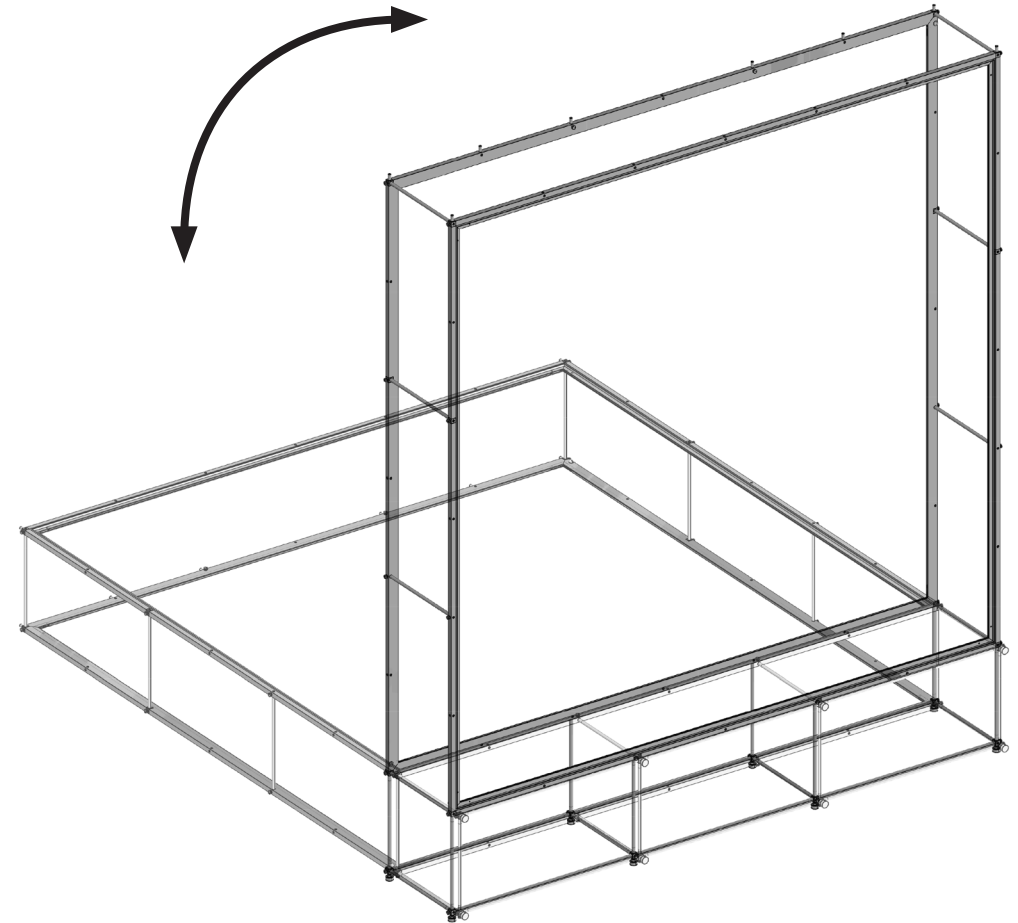

12

CONNECT CEILING PROFILE TO TUBES  
MAGNETICALLY

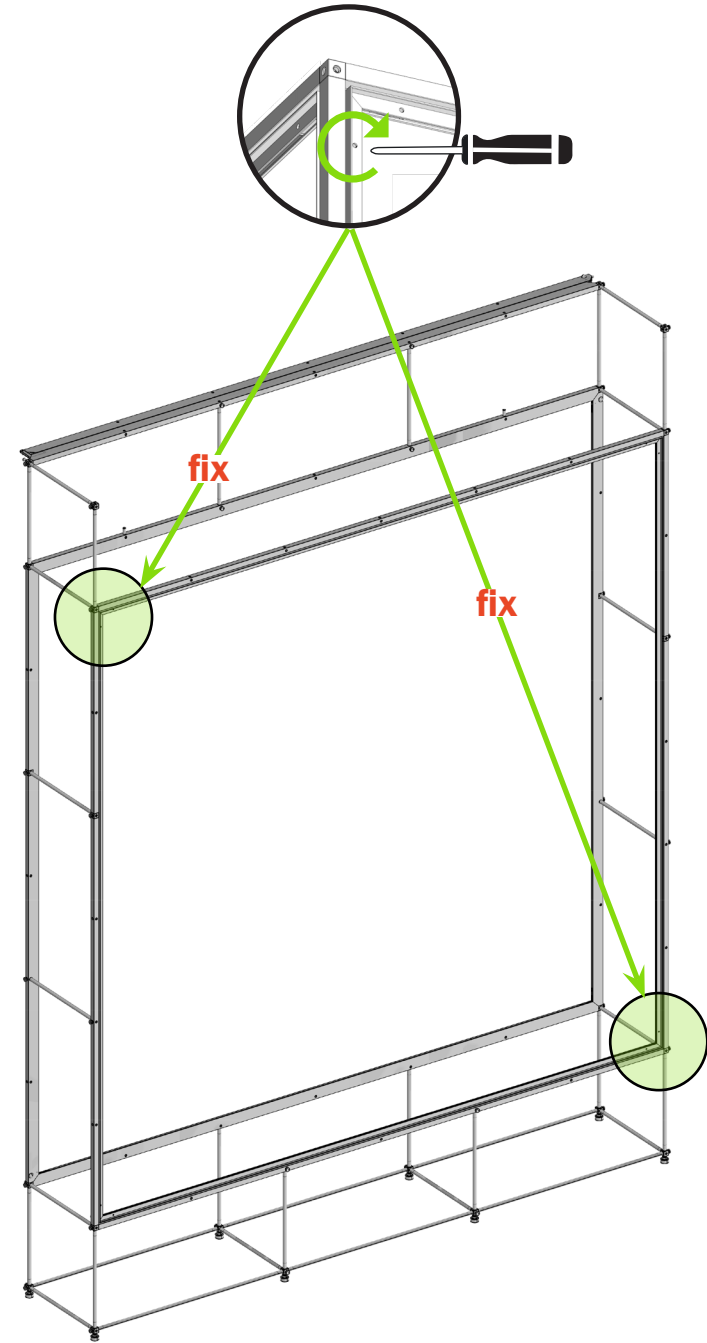
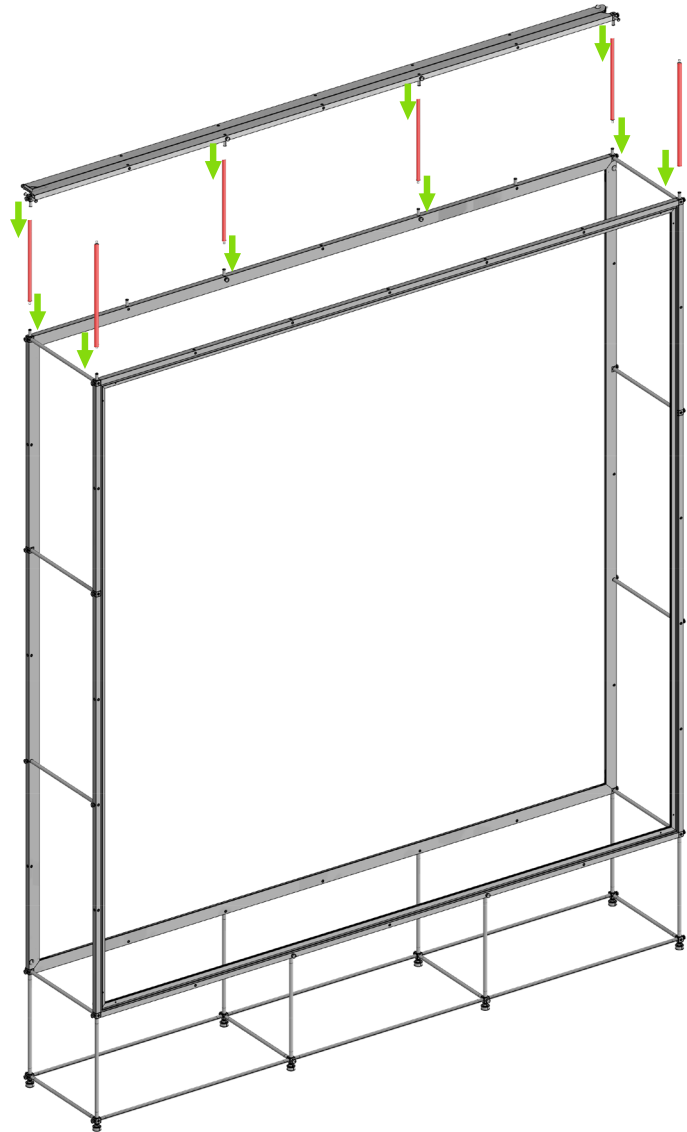



# VICTOR

## ASSEMBLING INSTRUCTIONS

**13**

**ADJUST HEIGHT  
BEFORE ASSEMBLING DIAGONALS**

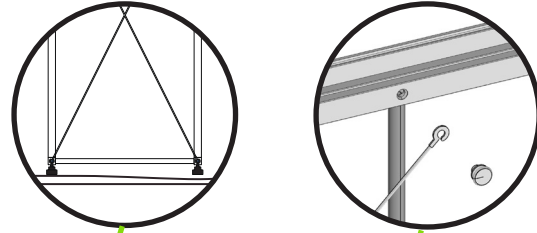

**14**

**TIGHTEN SCREWS  
AFTER ASSEMBLING  
ALL DIAGONALS**

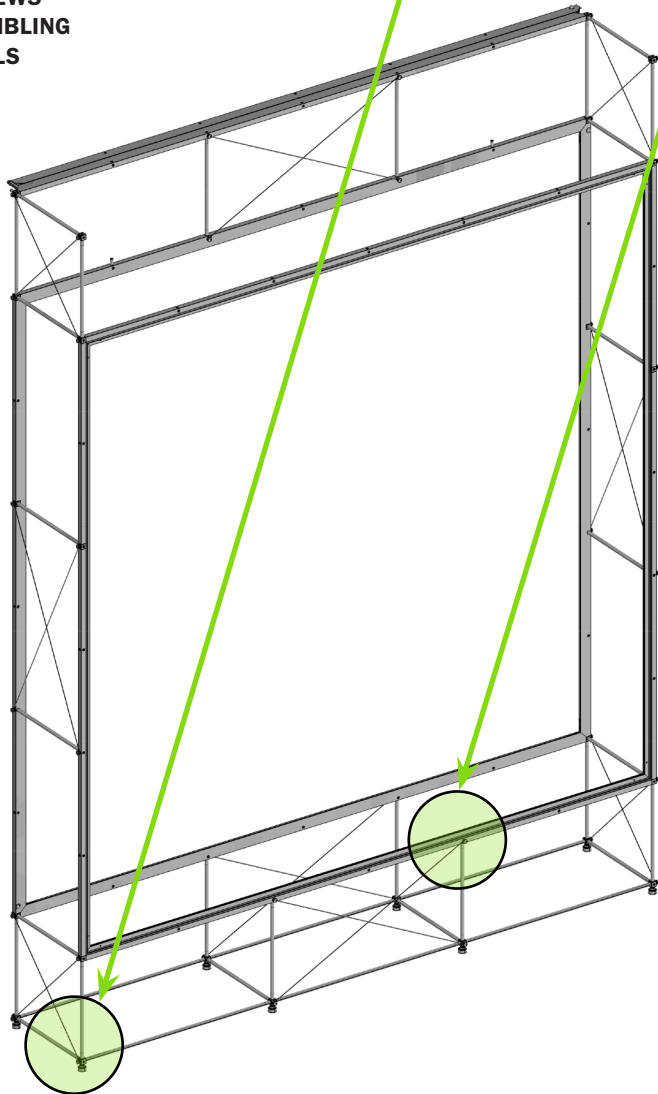

**15**

**ATTACH CEILING PROFILE  
AFTER POSITIONING THE UNITS**

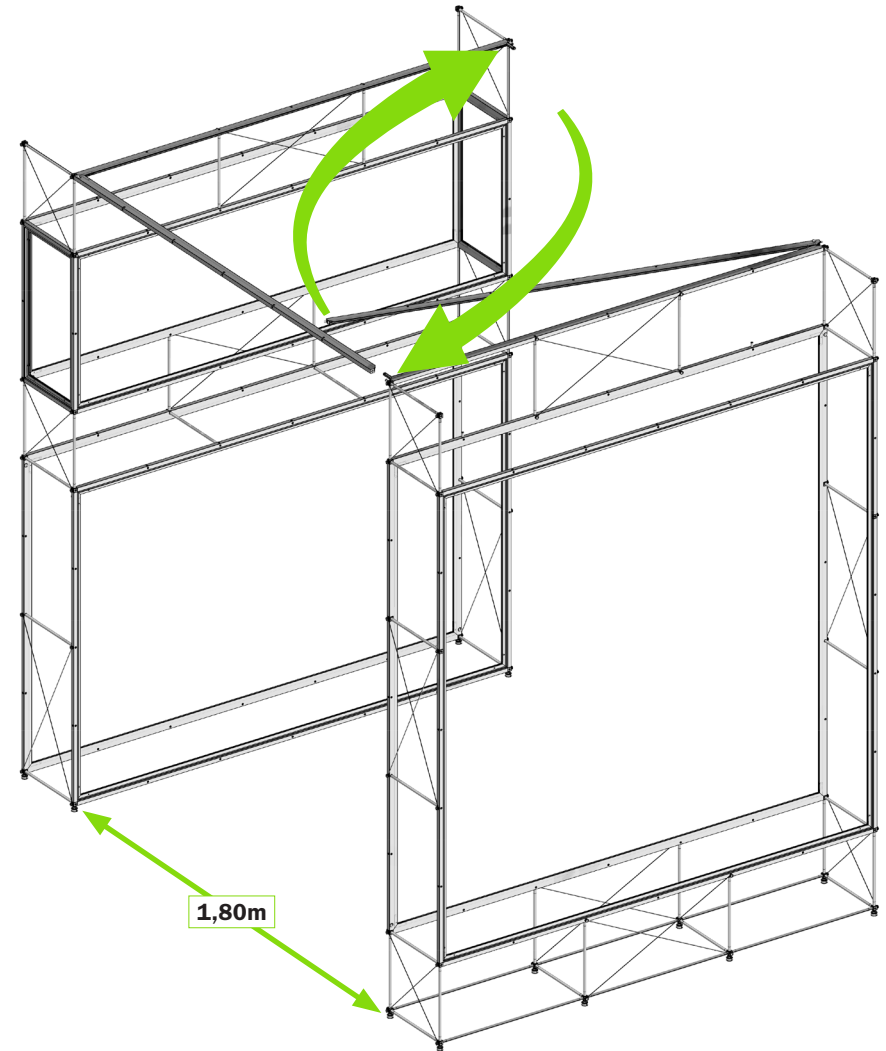

# VICTOR

## ASSEMBLING INSTRUCTIONS

16

EQUIPE THE UNIT

1 ASSEMBLE SHELVES

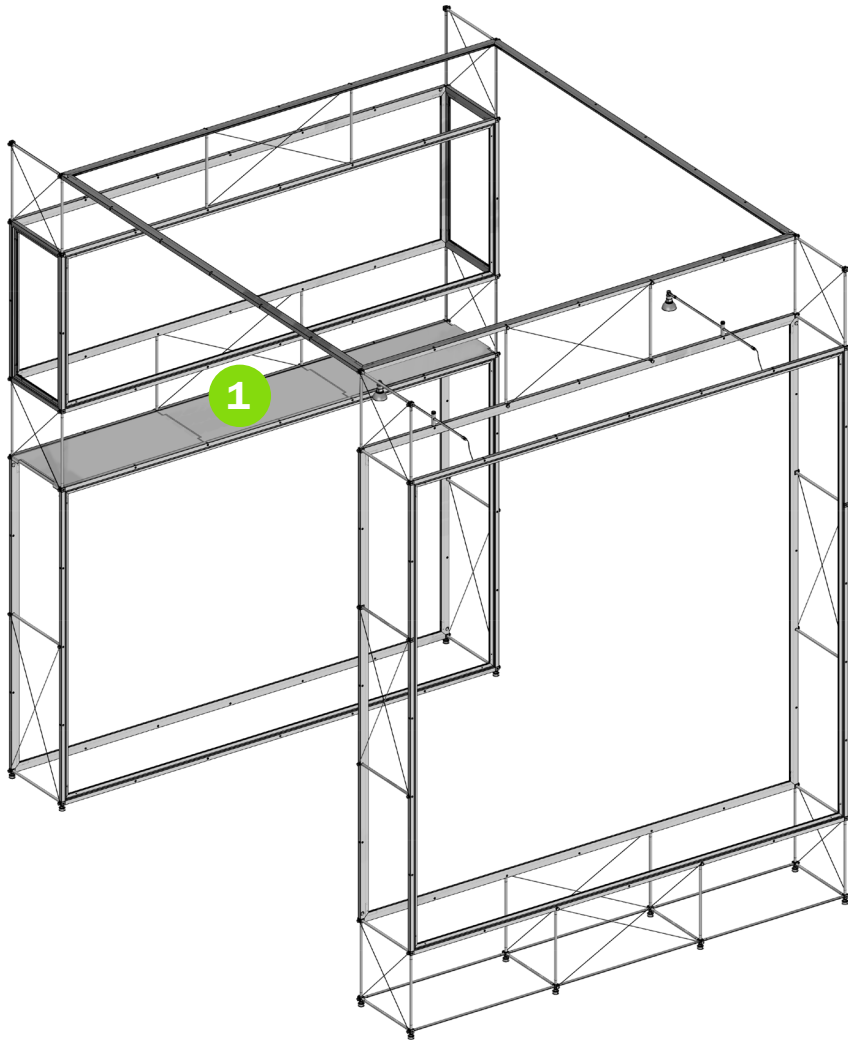

17

ATTACH FABRIC PANELS

- Attach top corners **1** and **2**
- Fix top edge and hang the fabric
- Attach corners **4** and **5**
- Put in fabric silicone in order of **6, 7, 8**

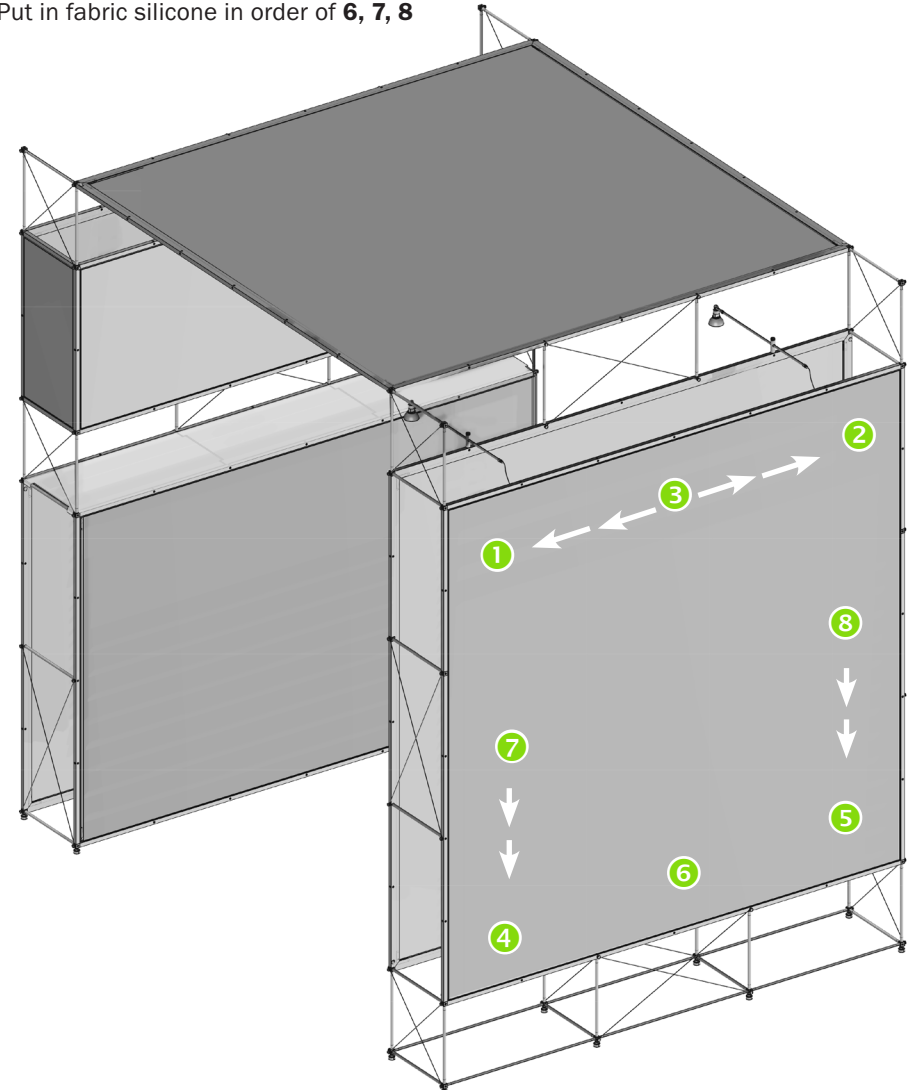

# VICTOR

## ASSEMBLING INSTRUCTIONS

---